



Orifice Plate & Orifice Flange



www.azaransanjesh.com



info@azaransanjesh.com

Description:

If a pipeline (through which a medium flows) is reduced at a particular point by a cross sectional constriction, the flow speed of the measured medium is increased at that point. According to Bernoulli's energy equation and the law of continuity, the total flow head (dynamic velocity head and static pressure head) is constant.

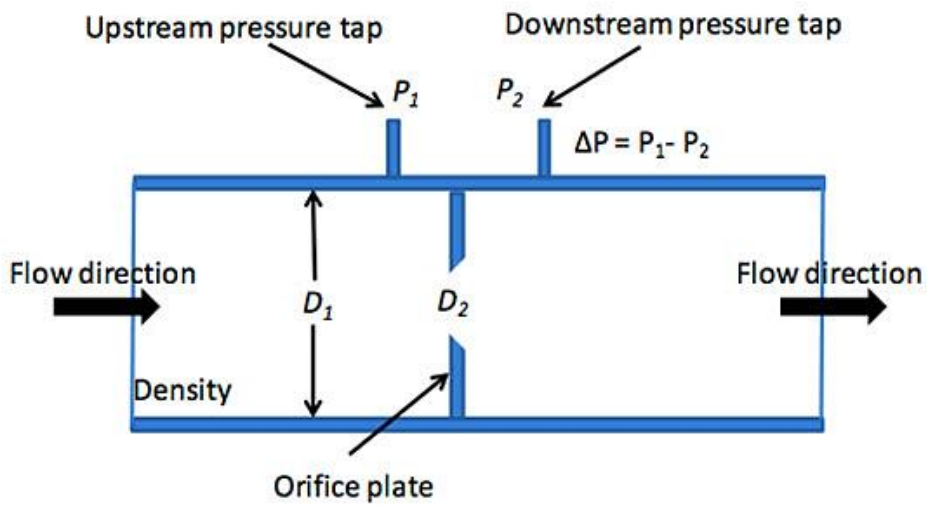
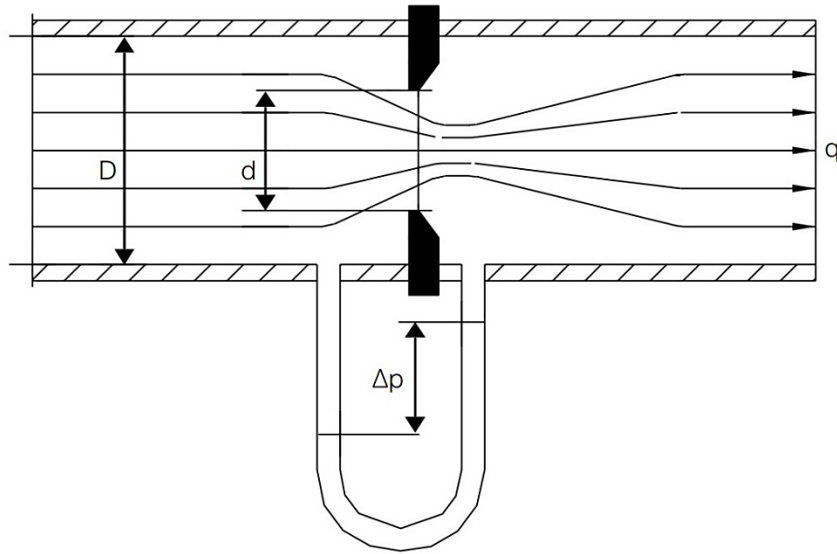

Figure 1: Orifice Plate Principles

The increase in speed at the constriction causes a reduction in the static head. The resulting pressure drop is called the **differential pressure head**; it is a measure of the flow (volume per unit of time or mass per unit of time).

$$q = \sqrt{\frac{2}{1 - \left(\frac{D_2}{D_1}\right)^2}} \times \sqrt{\frac{P_1 - P_2}{\rho}} \quad \text{Or} \quad q = c\sqrt{\Delta p}$$

ρ : density of flow , c : Constant

The flow rate (q) is a function of the square-root of the differential pressure head (Δp), where (c) is the coefficient of flow rate determined by the shape of the differential pressure transducer and the operating data. The pipeline may be constricted with orifice plates. The shape and manufacturing tolerances of plates used in measurement applications are defined in the international standardization publications of **ISO**, **AGA**, **ASME** and others. From the formulas and data within these publications, the relationships and values of flow, differential pressure, and plate bore are determined. **(Our Reference is ISO 5167-2:2003)** . In flow control applications, orifice plates are used as restriction devices to regulate fluid flow or reduce the flowing pressure downstream of the orifice plate. The use of a fixed restriction orifice can be beneficial and economic by reducing the demands on other flow system components.

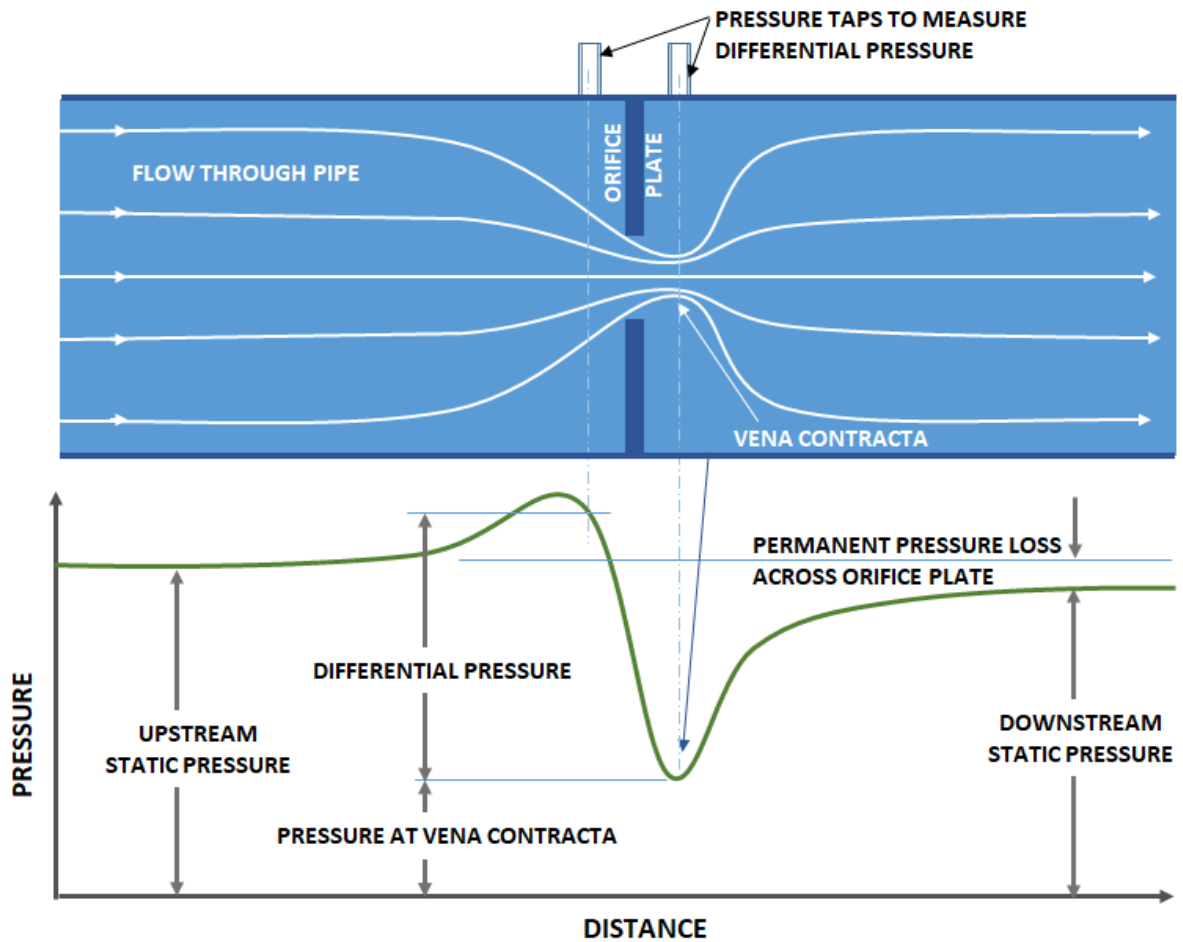

Figure 2: Pressure Drop Behavior

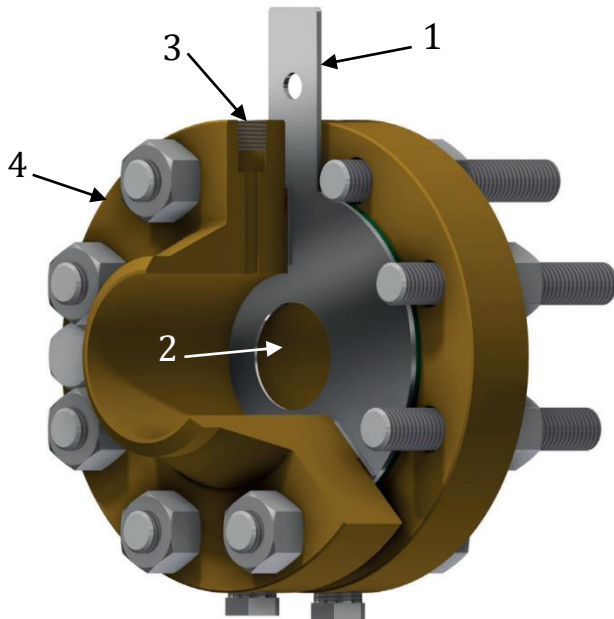

Figure 3: Cross section of Orifice assembly

1. Orifice Plate 2. Hole in Plate 3. Tapping 4. Orifice flange



Figure 4: Several types of Orifice Plates

Different Types of Orifice Plates:

1. Concentric orifice plate:

These are most commonly used for flow measurement. This has special features such as simple structures, high accuracy, and ease of installation & replacement. The orifice plates are correctly finished to the dimensions, surface roughness, and flatness to the applicable standard. These plates are recommended for clean liquids, gases & steam flow, when the Reynold number ranges from 10000 to 10^7 .

2. Quadrant Edge orifice plate:

The quadrant edge bore is an orifice with the inlet edge rounded. The upstream side of the bore is shaped like a flow nozzle while the downstream side acts as a sharp edge orifice plate. This design is recommended to measure the flow of high viscosity fluids such as heavy crudes, syrups and slurries. The quadrant bore produces a relatively constant coefficient when the Reynolds Number is below 10,000.

3. Eccentric Bore orifice plate:

Eccentrically bored orifice plates are plates with the orifice off-center, or eccentric, as opposed to concentric. The bore of the eccentric orifice normally is inscribed in a circle which is 98% of the pipe diameter, so that solids or slurries may pass through. Eccentric orifice plates are used in many industries including: heavy and light chemicals, steel, paper, nuclear and petrochemicals.

4. Segmental Bore orifice plate:

The segmentally bored orifice plates contain a hole that is a segment of a concentric circle. Like the eccentric orifice plate design, the segmental hole should be offset downward in gas flow applications. Segmental bores are generally used for measuring liquids or gases which carry non-abrasive impurities such as: sewage treatment, steel, chemical, water conditioning, paper and petrochemical industries.

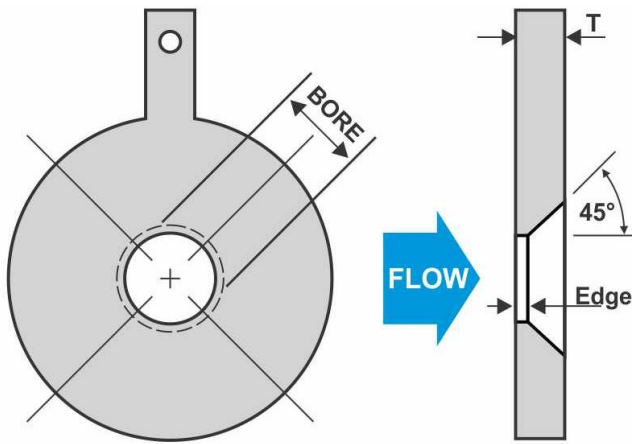

Figure 5: **Concentric** Orifice Plate

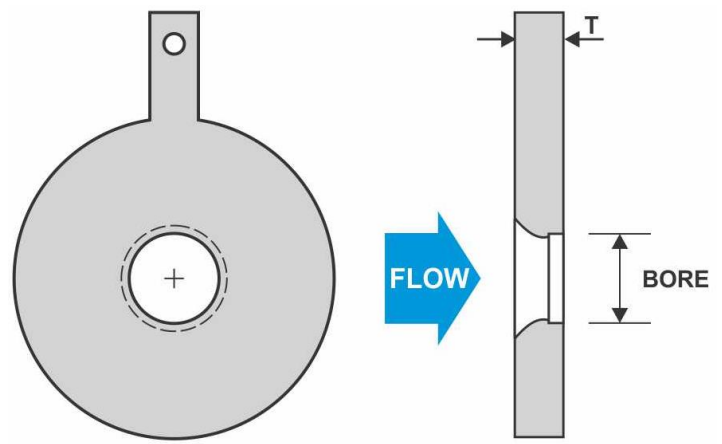

Figure 6: **Quadrant Edge** Orifice Plate

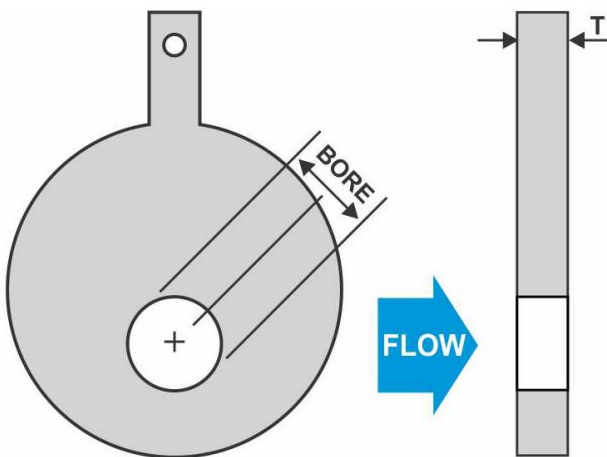

Figure 7: **Eccentric** orifice plate

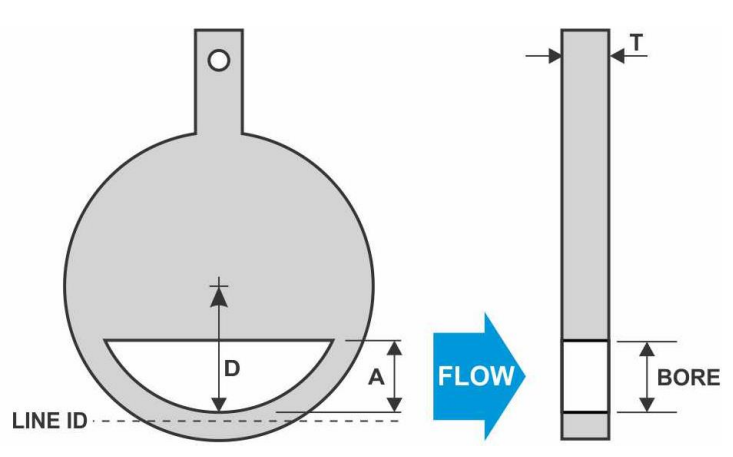

Figure 8: **Segmental** orifice plate

5. RTJ Type Orifice Plates:

The RTJ type orifice plate incorporates an integral gasket, either oval or octagonal ring, for mounting between ring type joint flanges (RTJ). It is based on proven technology, has no moving parts and is suitable for high temperature and pressure applications. Orifice plates are recommended for clean liquids, gases and low velocity steam flows. Plate thicknesses depend on line size and differential pressure, and should be sufficient to prevent the platen from bending under operating conditions. Orifice plates can be made in accordance with customer drawings as required. RTJ type orifice plates can be supplied complete with ANSI B16.36 orifice flanges.

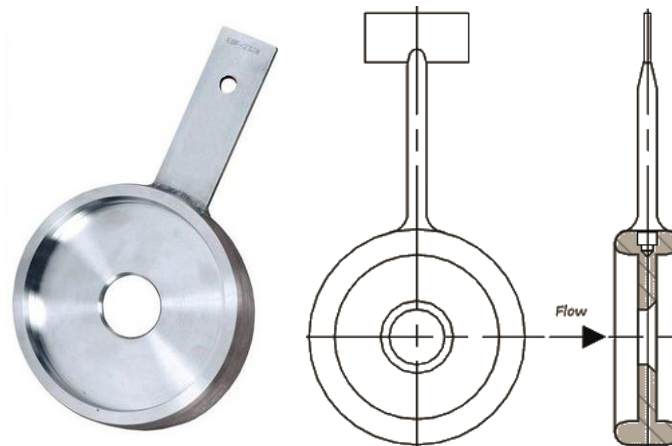

Figure 9: RTJ Type Orifice Plates

Materials:

Orifice plates may be machined in one piece, or alternatively from two pieces, with an orifice plate screwed onto a carrier ring/gasket. Standard material grades for orifice plates include: 316 Stainless Steel, 304 Stainless Steel, 310 Stainless Steel, Hastelloy C276, Monel 400, Carbon Steel, Titanium, Inconel 600 and Inconel 625. Common carrier ring/gasket materials include Stainless Steel and soft iron. To ensure correct sealing when installed between flanges, the hardness of the carrier ring/gasket material is limited to a maximum value, typically 120 for soft iron rings and 160 for Stainless Steel Rings.

Pressure Tappings:

Several standards exist for orifice pressure tap locations. Ideally, the upstream pressure tap will detect fluid pressure at a point of minimum velocity, and the downstream tap will detect pressure at the vena contracta (maximum velocity). In reality, this ideal is never perfectly achieved.

An overview of the most popular tap locations for orifice plates is shown in the following illustration:

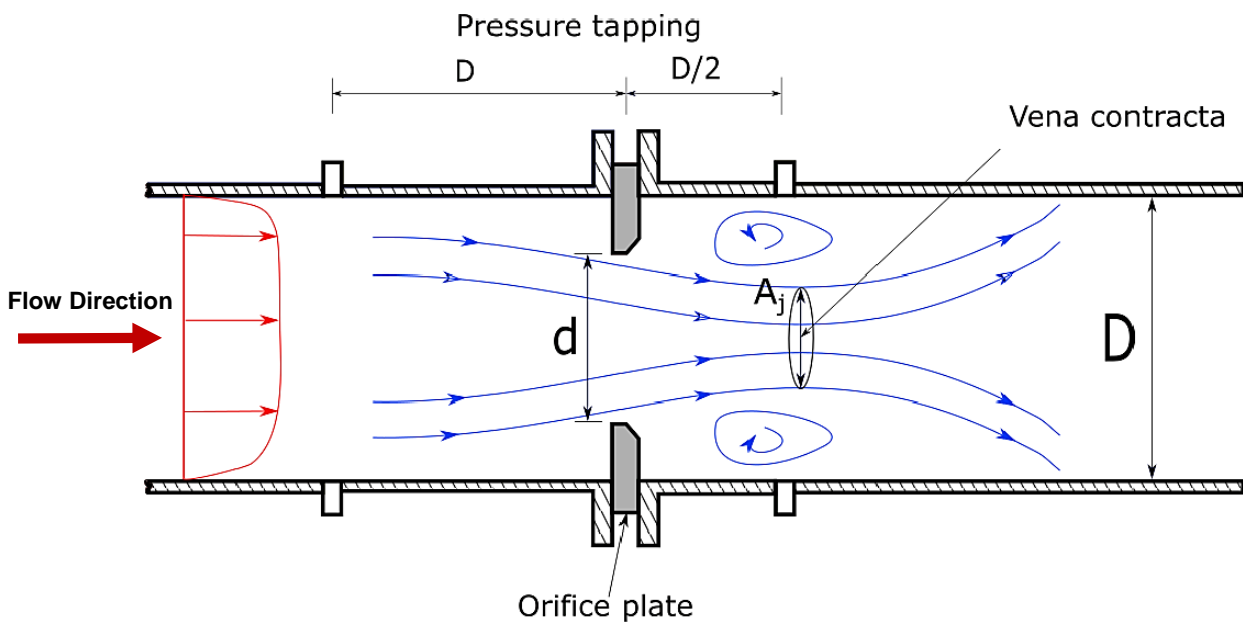
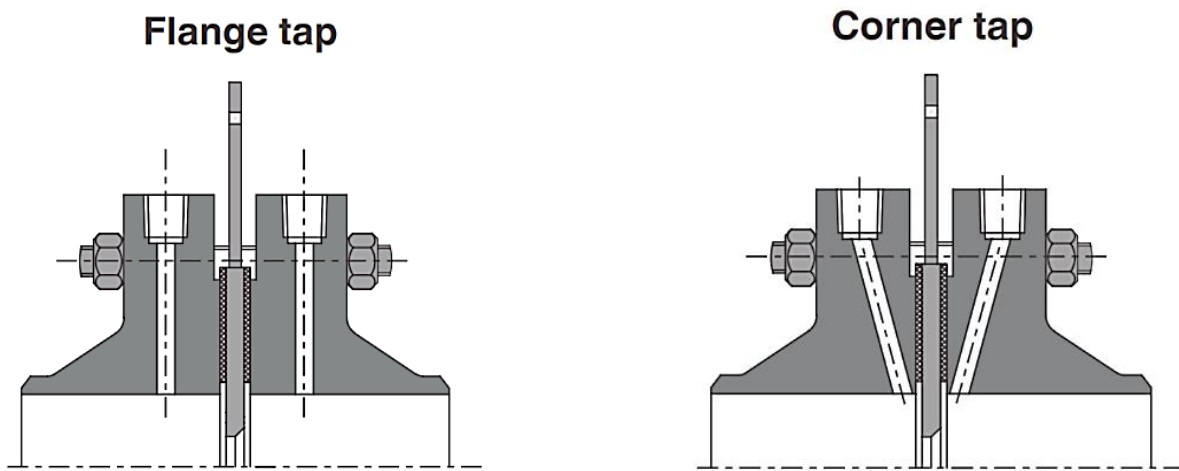

Figure 10: Different Types of Pressure Tapping

Ordering information's		
Model	Suffix Code	Description
Orifice Plate & Flange Assembly	OSL-P	Plate Only
	OSL-F	Flange Assembly(Bolt, Nut, Gasket Included)
Tap Type (Only for OSL-F series)	A	Pipe Tap D - D/2
	C	Flange Taps , 1/2NPTF
	D	Corner Taps, 1/2NPTF
Nominal Pipe Size	XXX	Pipe size in inch or mm
Material: Plate / Flange	CS	Carbon Steel
	S4	Stainless Steel 304L
	S6	Stainless Steel 316L
	SP	Special
Flange Rating	R01	ANSI Class 150 Raised Face
	R02	ANSI Class 300 Raised Face
	R03	ANSI Class 600 Raised Face
	R04	ANSI Class 900 Raised Face
	R05	ANSI Class 1500 Raised Face
	R06	ANSI Class 2500 Raised Face
	R07	DIN PN10
	R08	DIN PN16
	R09	DIN PN25
	R10	DIN PN40
	R11	DIN PN63
	R12	DIN PN100
Orifice Flange Type	WN	Weld Neck
	SW	Socket weld
	SO	Slip On
	XX	Special
Options	10	Tag Plate Included
	20	2 way Valve manifold
	30	3 way Valve manifold
	40	5 way Valve Manifold
	50	6 way S.S. Condensate Chambers, 1/2" NPT-F
	60	4 way S.S. Condensate Chambers, 1/2" NPT-F



Contact us:

Add: Unit 406, 4th Floor, No. 378, After Mirzaye Shirazi Int, Shahid Motahari Ave,
Tehran, Iran - Postal Code: 15866-94945

Website: www.azaransanjesh.com

Email: info@azaransanjesh.com

Phone No.: +98 21 88 31 00 81-2

Mobile No.: +98 912 432 1814

Fax No.: +98 21 888 33 944

Whatsapp: +98 912 432 1814



www.azaransanjesh.com



info@azaransanjesh.com